

Emergency Cylinder Shutter for highly pressurized dangerous gases

ECS1 is an automatic mechanical shut-off system. Dangerous, flammable or toxic gases are applied in numerous industrial processes. ECS1 is a highly efficient method of switching off dangerous gases directly at the source in emergency situations. It is designed to prevent gas explosion and gas poisoning caused by leakage of highly pressurized gases.

Safety starts with the gas bottle

The ECS1 is very easy to install and is mounted on the gas cylinder. This ensures maximum safety directly at the source cylinder.

Compatible with common gas cylinders

ECS1 is compatible with common cylinders and valve types such as CEODEUX and Kohda due to a clamp connection and included adapters.

Upgrade your existing gas cabinets

A separately available control box, enables to easily retrofit your existing gas systems.

Robust design

High durability due to full metallic gear mechanism of the device.

ECS1 in action



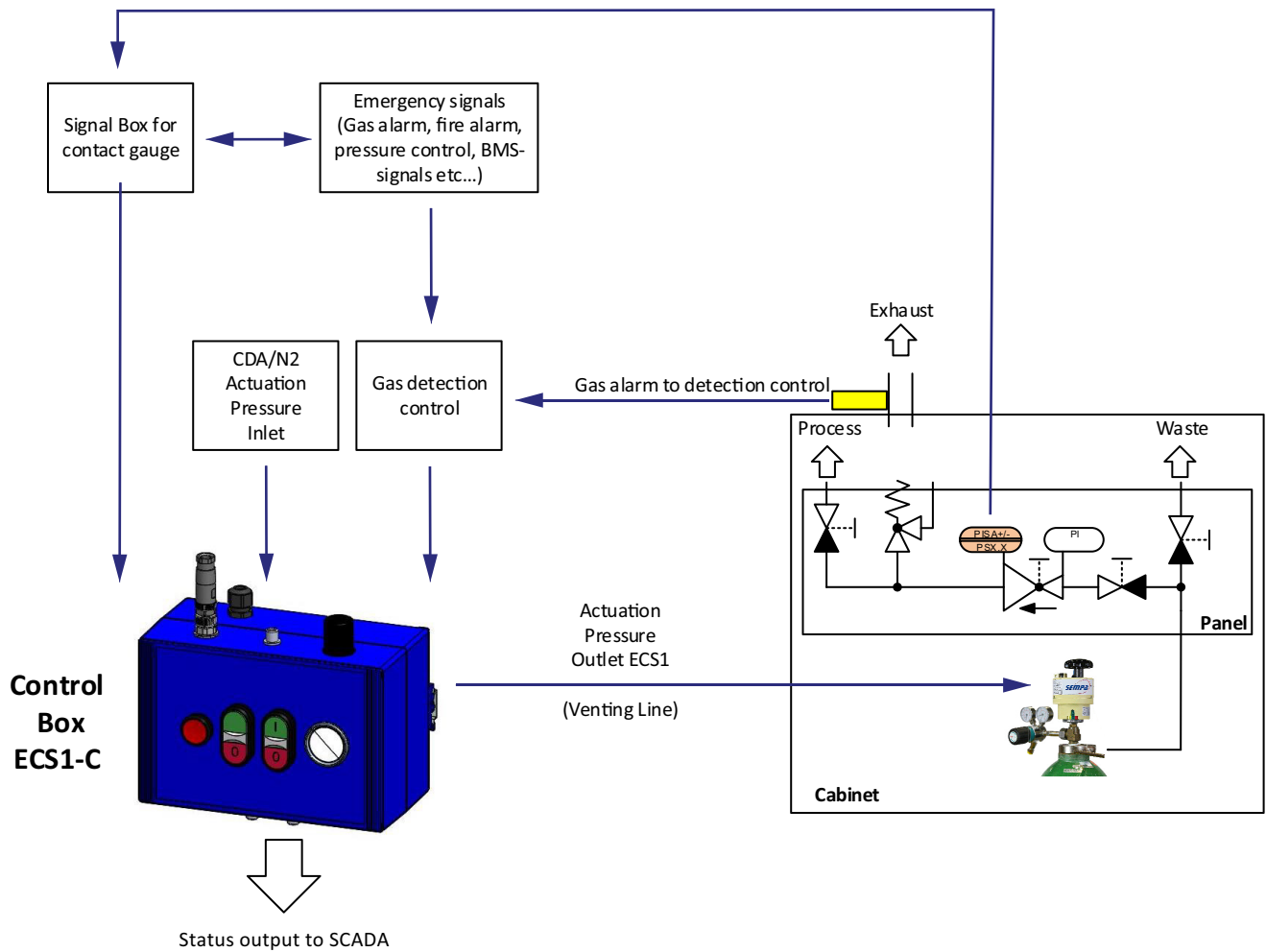

Technical Data

	ECS1	Control Box
Dimensions	120(W) × 135(D) × 254(H) mm	240(W) × 120(D) × 160(H) mm
Weight	3.0 kg approx	3.0 kg approx
Operation / Interface	Manual Valve opening Spring loaded closing mechanism	0 – 250V dry contact
Reaction time (valve closing)	< 100 ms	-----
CDA pressure range	3 – 5 bar g	3 – 5 bar g (> 5 – 10 bar g pressure regulator)
Power supply	-----	100V – 240 V / 50 – 60Hz (0.35 A)
CDA inlet dimension	6 mm quick connect (PE 6 × 4)	6 mm quick connect (PE 6 × 4)
Torque during shutting	8.8 – 12 Nm	-----
Certifications	CE	CE